

BRUKSVARA

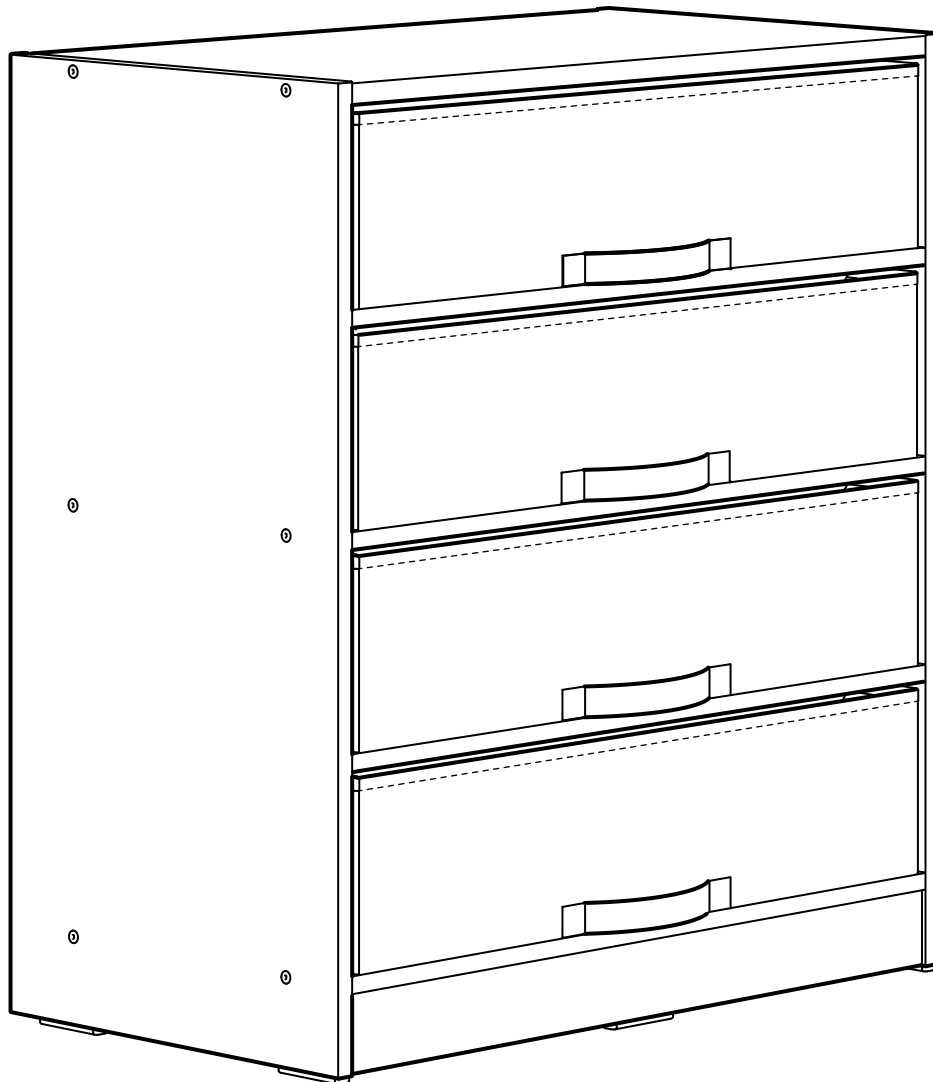

Design and Quality
IKEA of Sweden



English

WARNING

Serious or fatal crushing injuries can occur from furniture tip-over.

ALWAYS secure this furniture to the wall using tip-over restraints.

To further reduce the risk of serious injury and death from tip-overs:

- Place heaviest items in the lower drawer.
- Do not set TVs or other heavy objects on top of this product.
- Never let children climb or hang on drawers, doors, or shelves.

Español

ADVERTENCIA

Si el mueble vuelca, puede provocar lesiones muy graves e incluso mortales.

Fija SIEMPRE este mueble a la pared utilizando los accesorios antivuelco.

Para reducir aún más el riesgo de lesiones graves o incluso mortales causadas por el vuelco del mueble:

- Guarda los objetos más pesados en el cajón inferior.
- No pongas un TV u otros objetos pesados encima de este producto.
- Evita que los niños suban encima del mueble o se cuelguen de los cajones, las puertas o los estantes.

Portugues

IMPORTANTE

A queda de móveis pode provocar ferimentos graves ou fatais.

Fixe SEMPRE este móvel à parede com acessórios de fixação.

Para reduzir o risco de ferimentos graves ou morte pela queda de móveis:

- Coloque os itens mais pesados nas gavetas mais baixas.
- Não coloque televisões ou outros objetos pesados em cima deste artigo.
- Nunca permita que as crianças subam ou se pendurem nas gavetas, portas e prateleiras.

中文

警告：

家具傾倒可能導致嚴重或致命的傷害。請務必使用防翻倒約束裝置，以便將家具固定在牆面上。為進一步降低家具翻倒而造成的重傷或死亡風險：

- 請將重物放在低層抽屜中。
- 請勿將電視機或其它重物放在該產品頂部。
- 請勿讓兒童攀爬或懸掛在抽屜、櫃門或擱板上。

繁中

警告：

如果家具傾倒，可能造成嚴重或致命的壓傷危險。務必使用固定配件，將此家具上牆固定。為能有效降低因家具傾倒造成嚴重傷害的危險：

- 將重物放在下層抽屜。
- 請勿把電視或其他重物放在此產品上方。
- 請勿讓兒童攀爬或掛在抽屜、門板或層板上。

한국어

경고!

가구 전복 사고로 인해 심각한 사고나 부상이 발생할 수 있습니다. 반드시 사고를 예방할 수 있는 고정부품으로 가구를 벽에 고정시켜주세요.

사고로 인한 부상과 인명사고를 줄이기 위해서는 아래쪽 서랍에 가장 무거운 물건을 넣어두고, 제품 위에 TV나 무거운 물건을 올려두지 말고, 절대로 아이들이 서랍이나 도어, 선반으로 기어오르거나 매달리지 못하게 해주세요.

日本語

警告

家具の転倒により、家具の下敷きになって大ケガ、あるいは生命にかかわるような傷害を負う危険があります。

本製品は、転倒防止用固定具を使用して、必ず壁に固定してください。

家具の転倒による大ケガや死亡事故のリスクを減らすために以下のことを守ってください。

- 重い物は下の引き出しに入れる。
- 本製品の上にテレビやほかの重い物を置かない。
- 絶対に子どもに引き出しや扉、棚板によじ登ったりぶら下がったりさせない。

Bahasa Indonesia

PERINGATAN

Cedera serius dapat terjadi akibat perabotan terjungkir.

SELALU kencangkan perabotan ke dinding dengan menggunakan alat pengencang.

Untuk mengurangi resiko cedera serius dan kematian akibat perabotan terjungkir:

- Letakkan barang yang paling berat di laci yang lebih rendah.
- Jangan meletakkan TV atau benda berat di atas produk ini.
- Jangan biarkan anak memanjat atau menggantung pada laci, pintu, atau rak.

Bahasa Malaysia

AMARAN

Kecederaan serius atau teruk yang membawa maut boleh terjadi akibat perabot rebah.

SENTIASA kukuhkan perabot pada dinding menggunakan penahan rebah.

Untuk mengurangkan risiko kecederaan serius dan kematian lebih lanjut akibat rebah:

- Tempatkan barang paling berat di dalam laci paling bawah.
- Jangan setkan TV atau objek berat lain di atas produk ini.
- Jangan biarkan kanak-kanak memanjat atau bergayut pada laci, pintu, atau para-para.

عربي

تحذير!

قد تحدث إصابات بالغة أو مميتة نتيجة انقلاب الأثاث. ثبت هذا الأثاث دائماً على الحائط بواسطة أدوات التثبيت المانعة للإنقلاب. لتقليل مخاطر الإصابة الخطرة والتعرض للموت نتيجة انقلاب الأثاث:

- ضع الأشياء الثقيلة في الدرج السفلي.
- لا تضع تلفزيون أو أي أشياء ثقيلة أخرى فوق هذا المنتج.
- لا تسمح أبداً للأطفال بتسلق أو التعلق على الأدراج، الأبواب، أو الأرفف.

ไทย

คำเตือน

หากตู้ล้มคว่ำ อาจก่อให้เกิดการบาดเจ็บร้ายแรงหรืออันตรายถึงชีวิต ควรยึดเฟอร์นิเจอร์เข้ากับผนังด้วยอุปกรณ์ยึดเพื่อความปลอดภัย เพื่อลดความเสี่ยงของการเกิดอุบัติเหตุและอันตรายร้ายแรงถึงชีวิต

ให้เก็บของหนักไว้ในลิ้นชักล่างสุดเสมอ ไม่วางโทรทัศน์หรือสิ่งของหนักๆ ไว้บนสินค้า และไปปล่อยให้เด็กปีนป่ายหรือห้อยโหนลิ้นชัก บานตู้ หรือชั้นวาง

Tiếng Việt

CẢNH BÁO!

Khi đồ nội thất bị ngã đổ có thể gây ra thương tích nghiêm trọng hoặc gây tử vong.

LUÔN cố định đồ nội thất vào thường bằng phụ kiện chống ngã đổ.

Để giảm nguy cơ bị thương tích nghiêm trọng hoặc tử vong do đồ nội thất ngã đổ:

- Đặt các vật dụng nặng nhất ở ngăn kéo dưới cùng.
- Không đặt bộ TV hoặc các vật dụng khác lên trên cùng của sản phẩm này.
- Tuyệt đối cho phép trẻ em đứng, leo trèo hoặc đu bám vào ngăn kéo, cửa hoặc giá kệ.

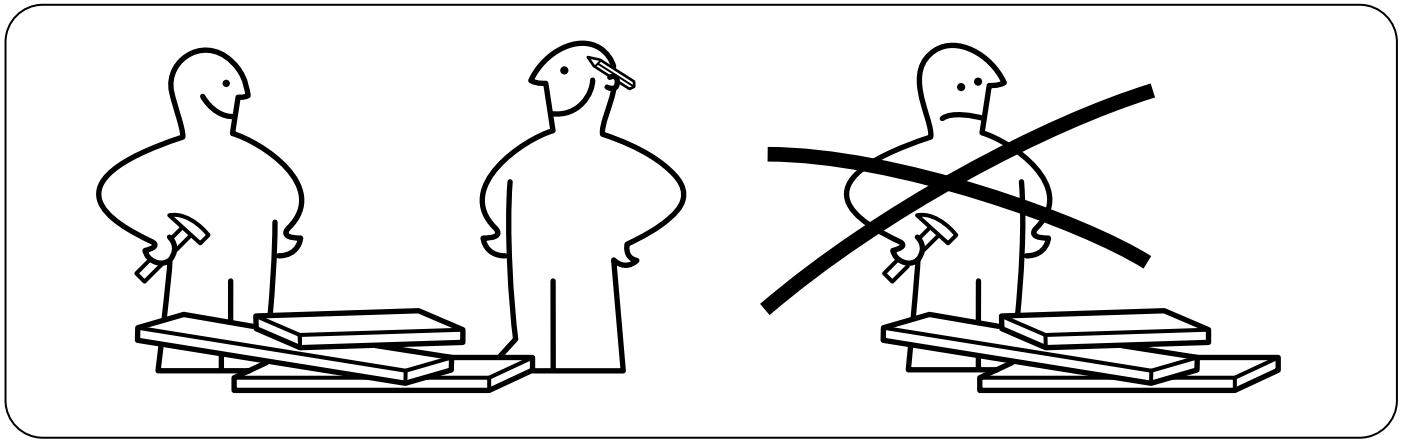
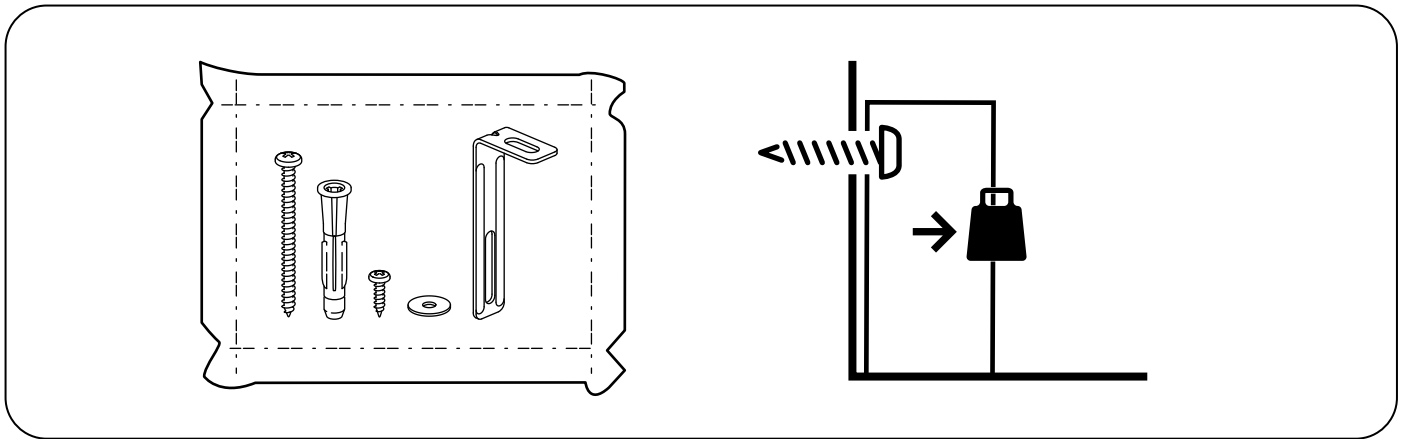
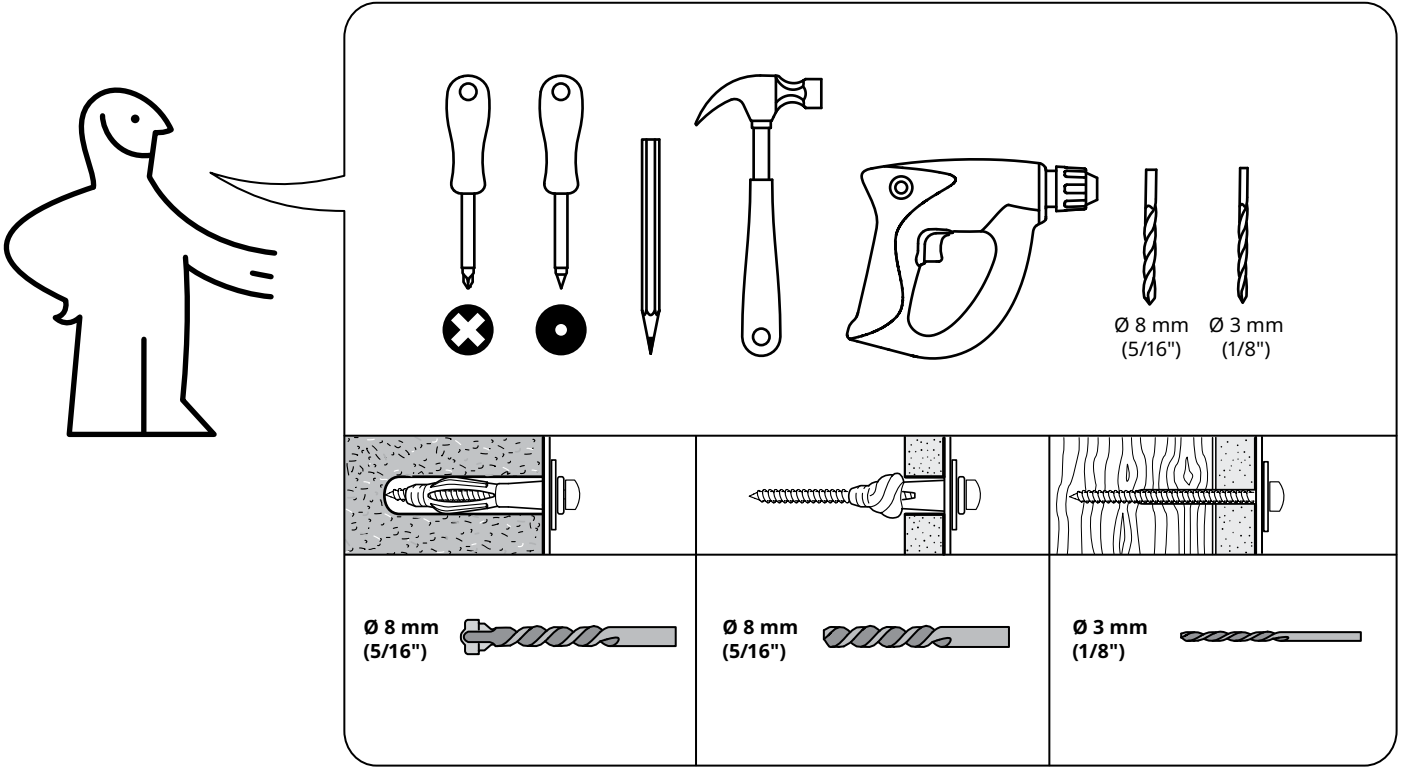

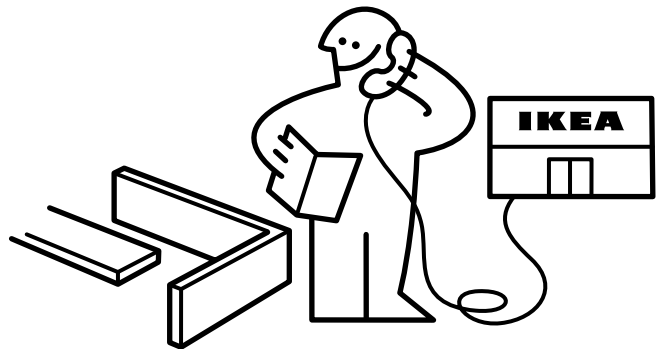
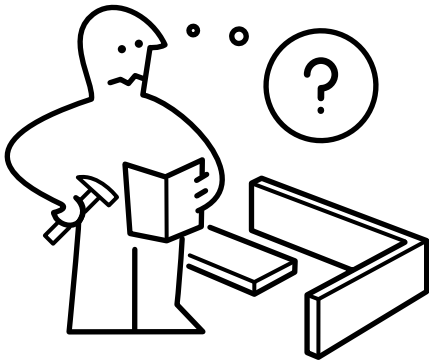
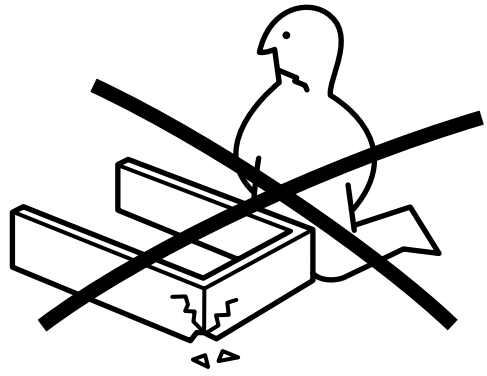
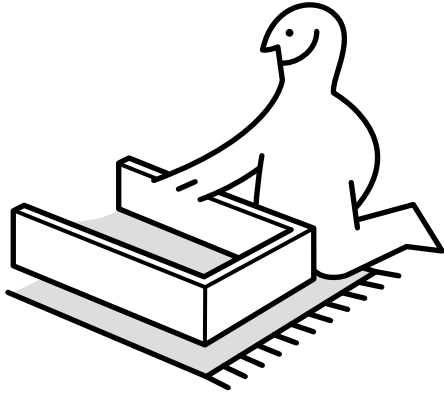

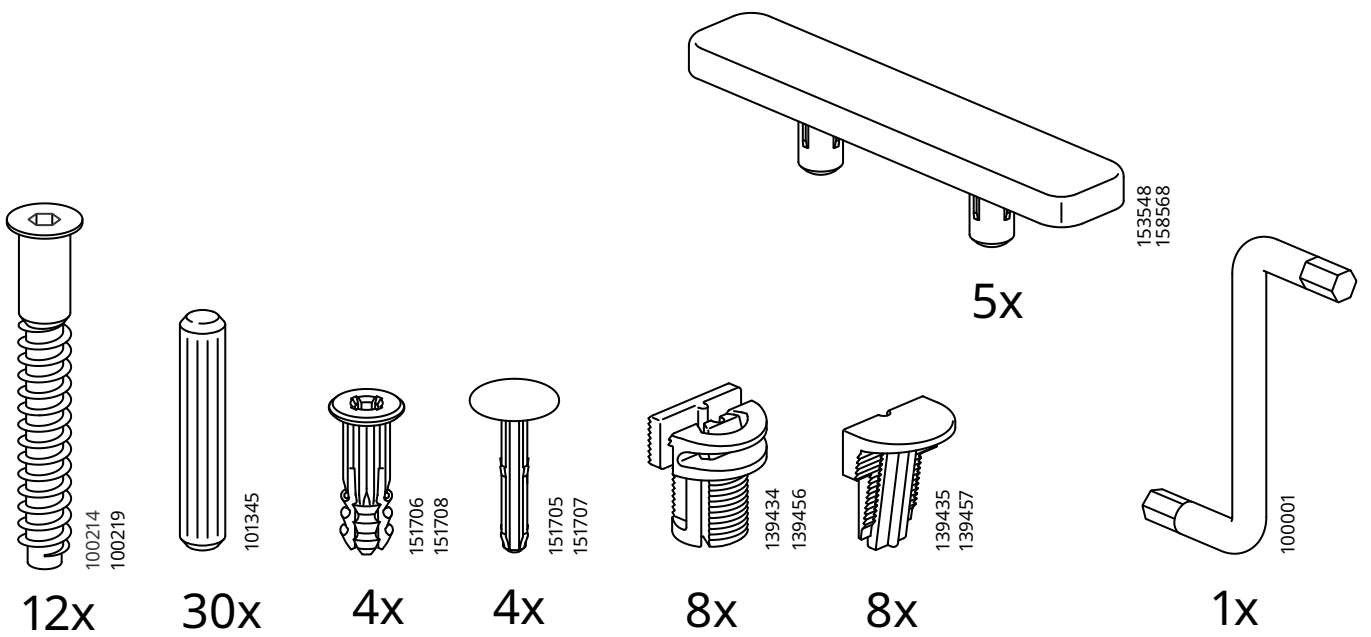
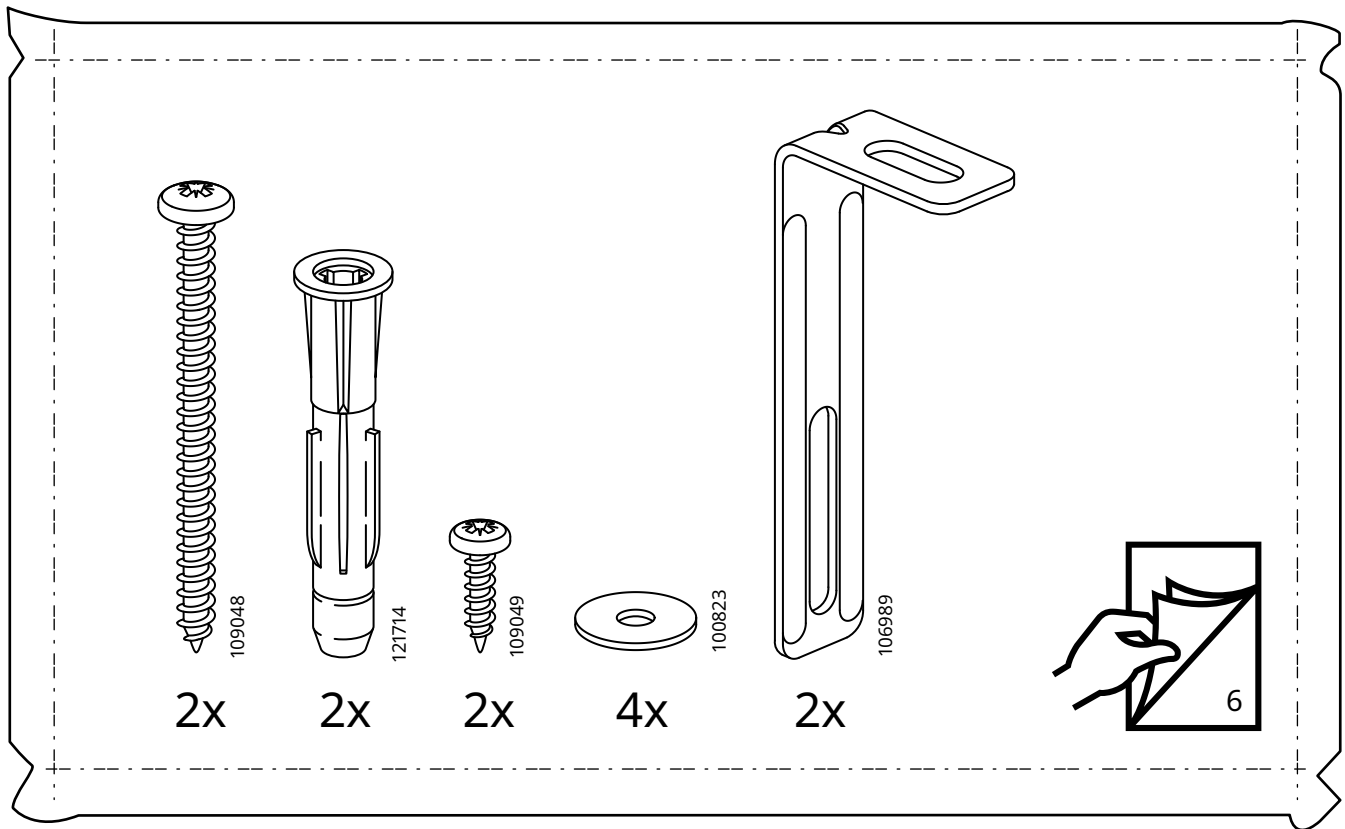

1

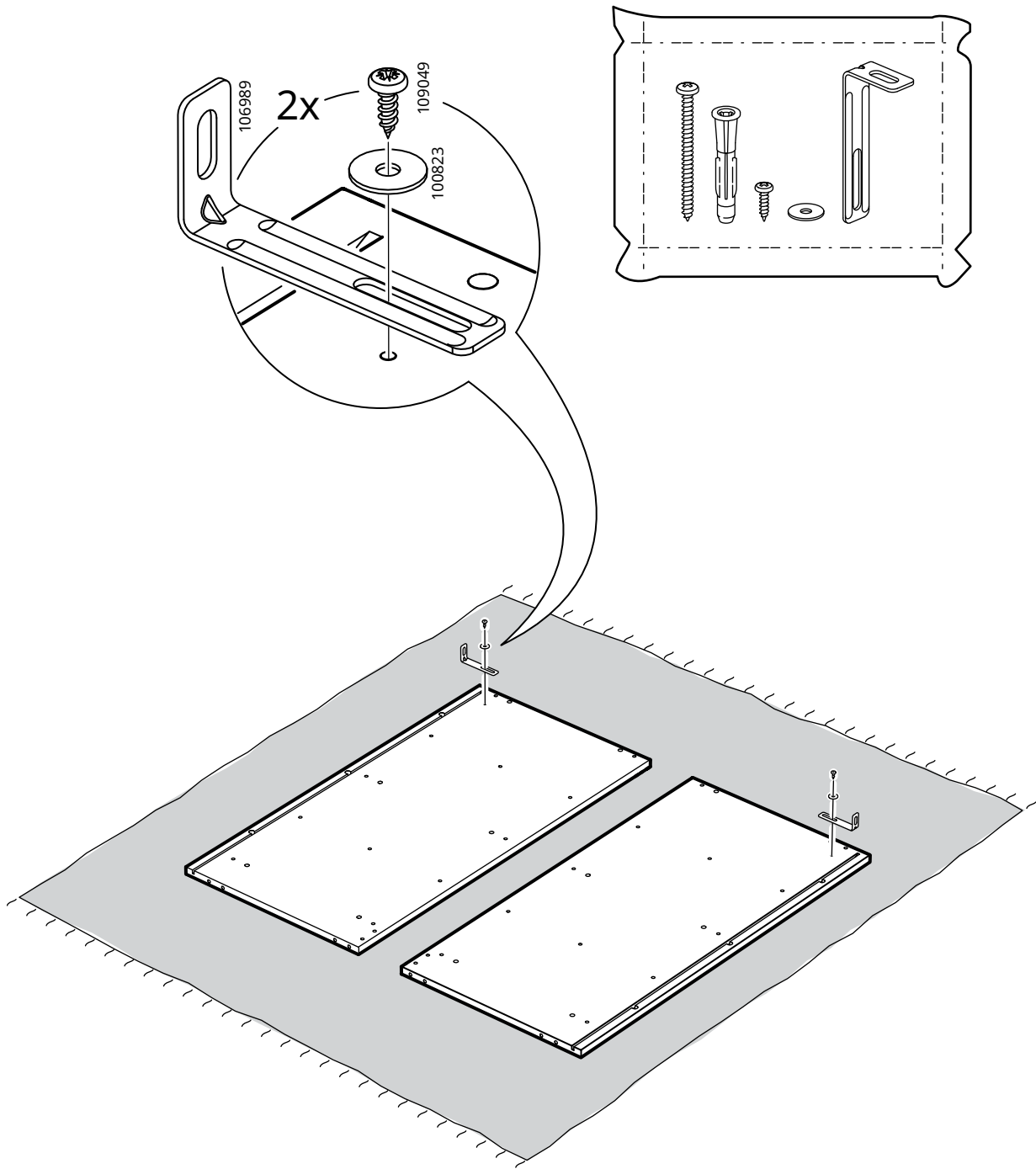

2

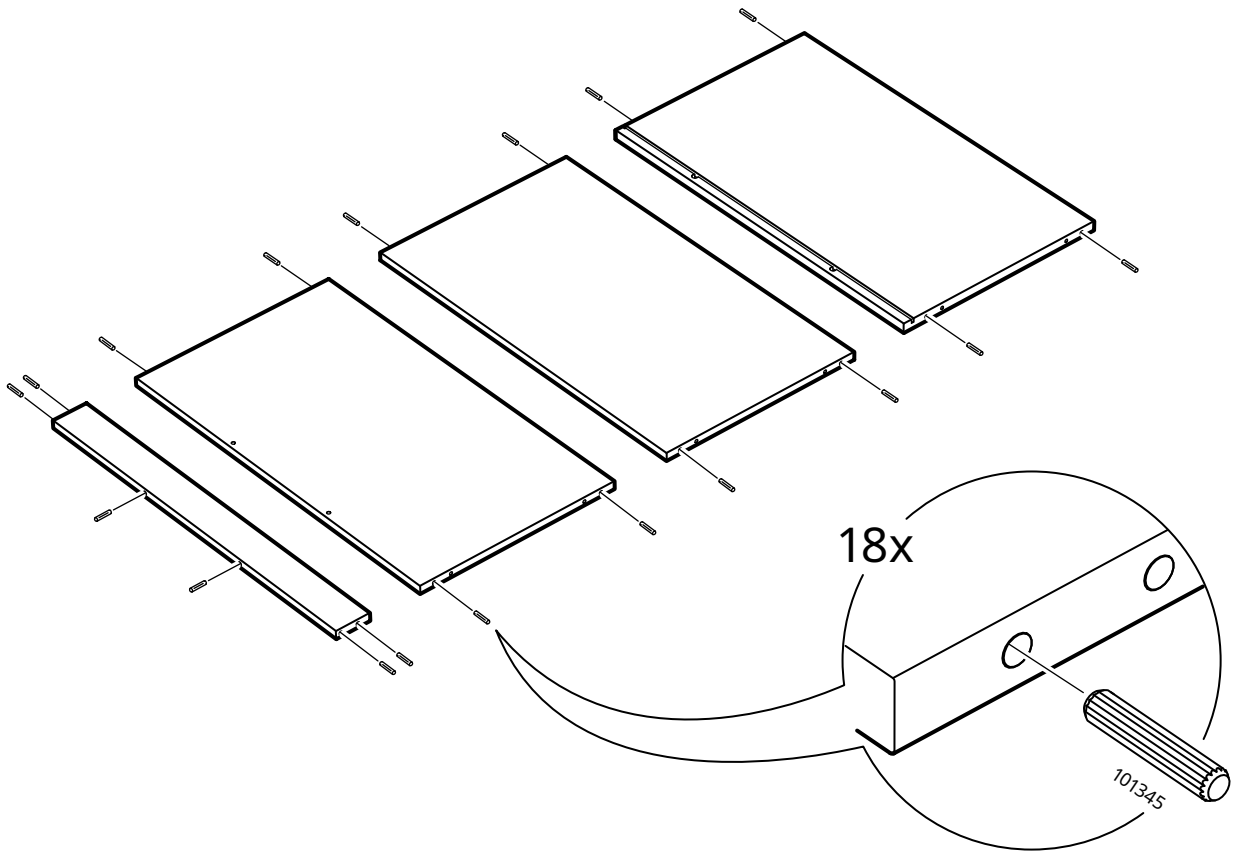

3

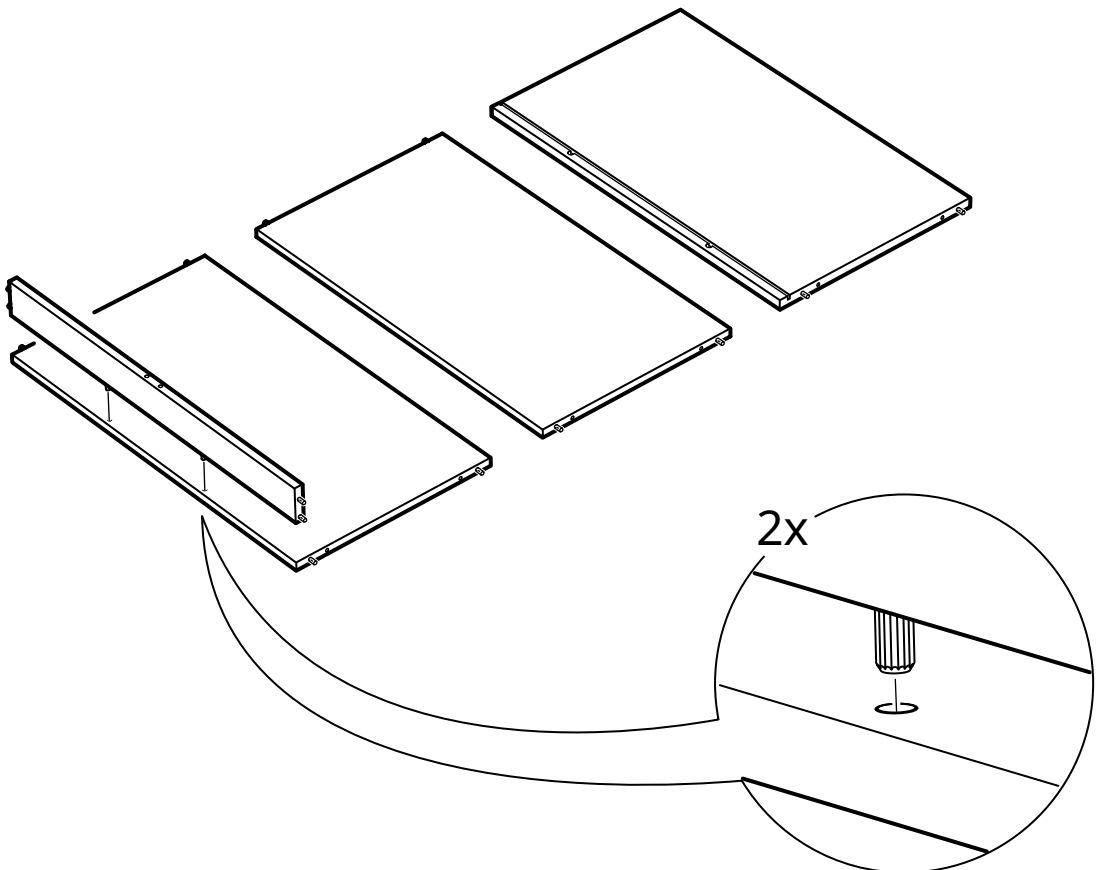

4

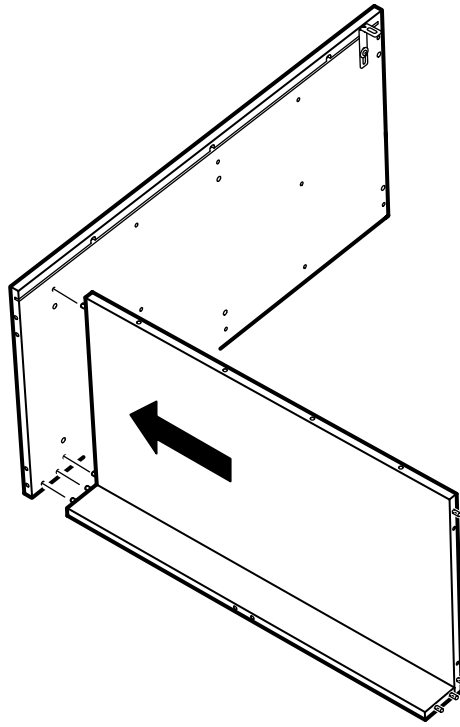

5

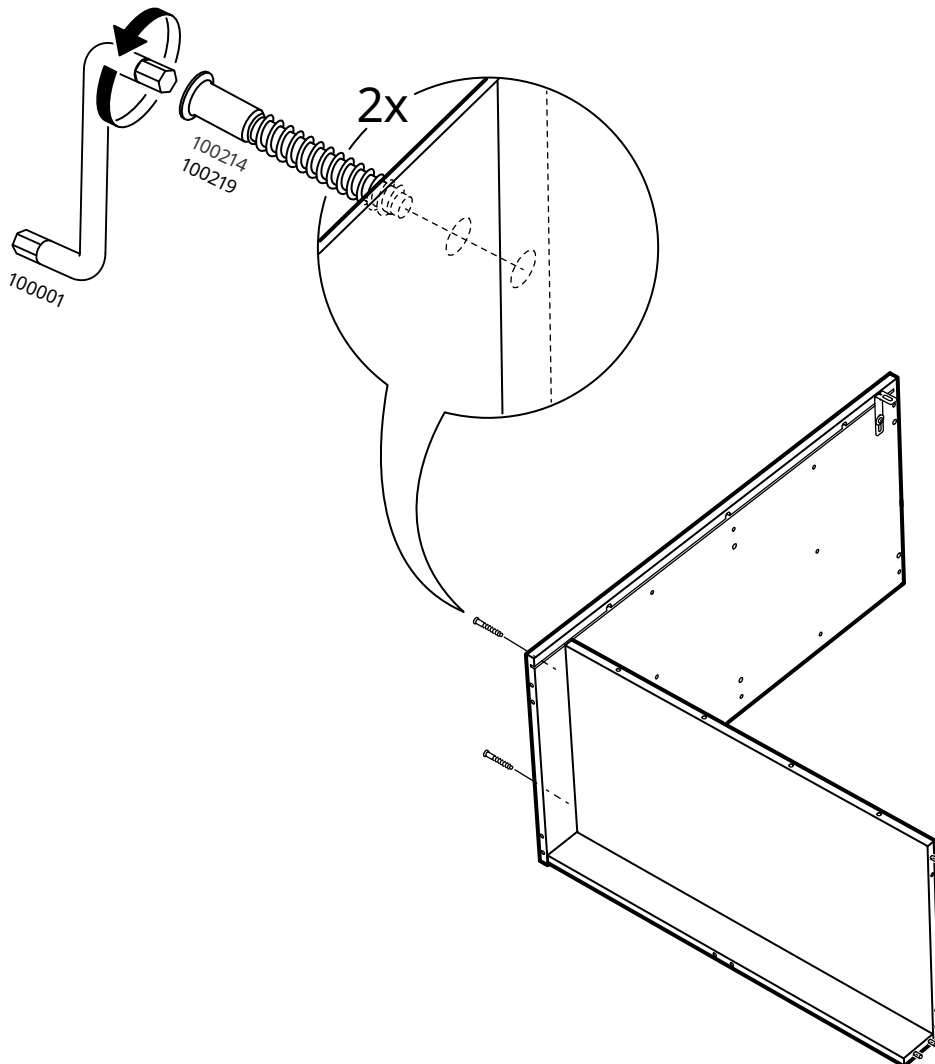

6

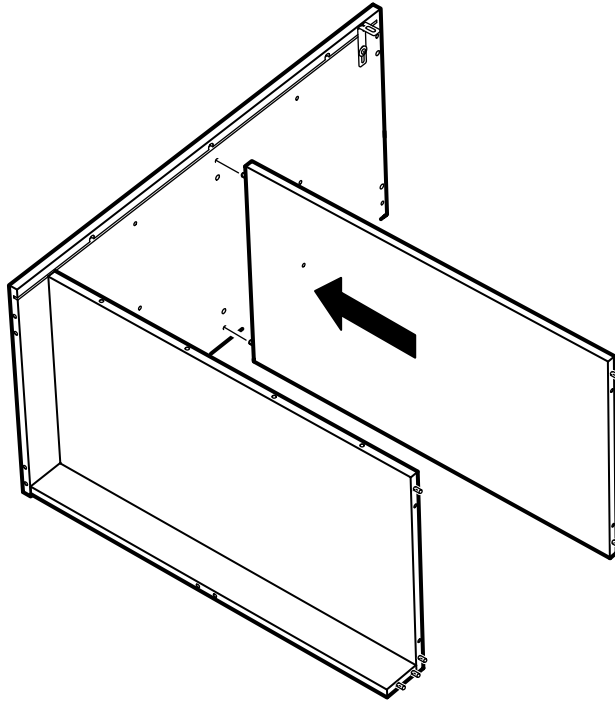

7

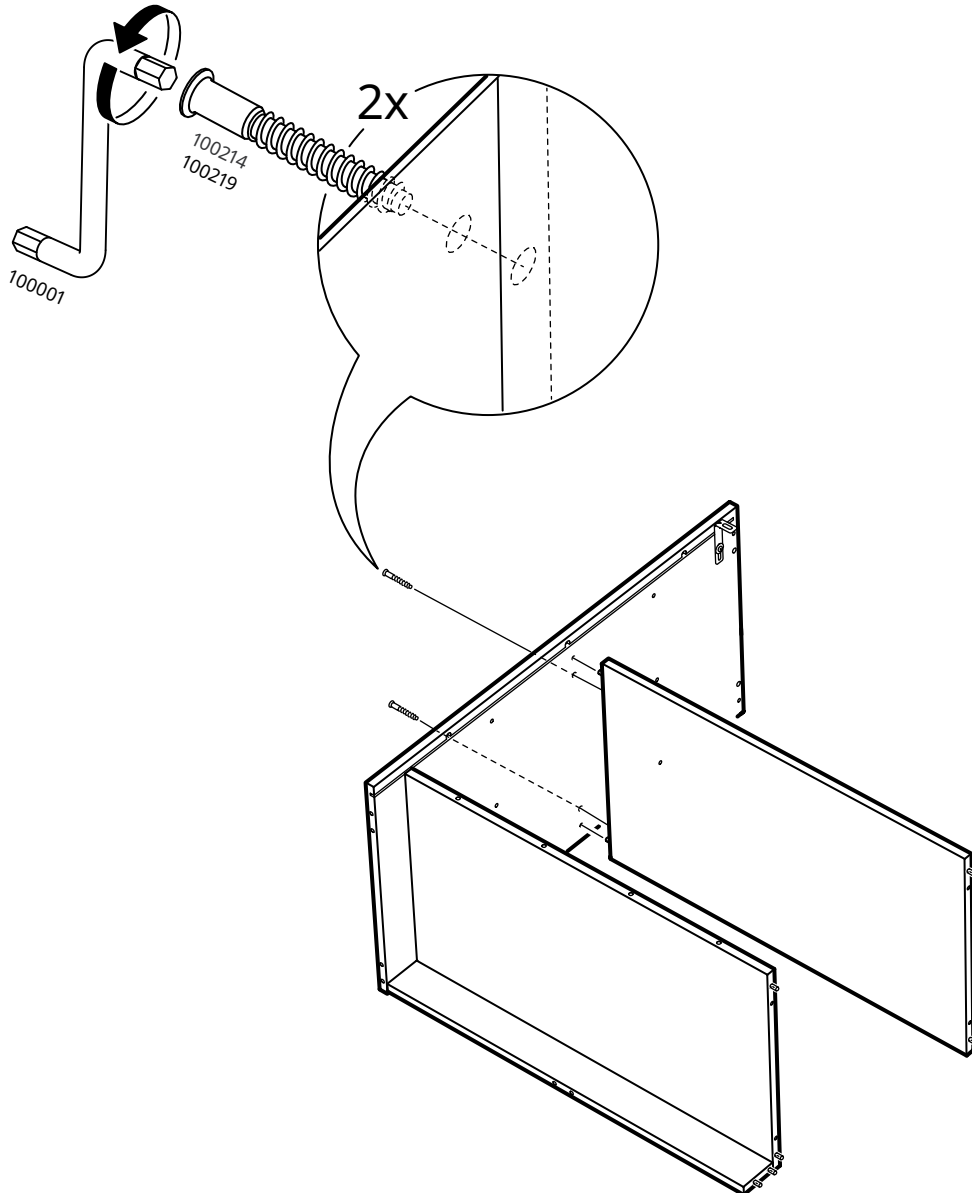

8

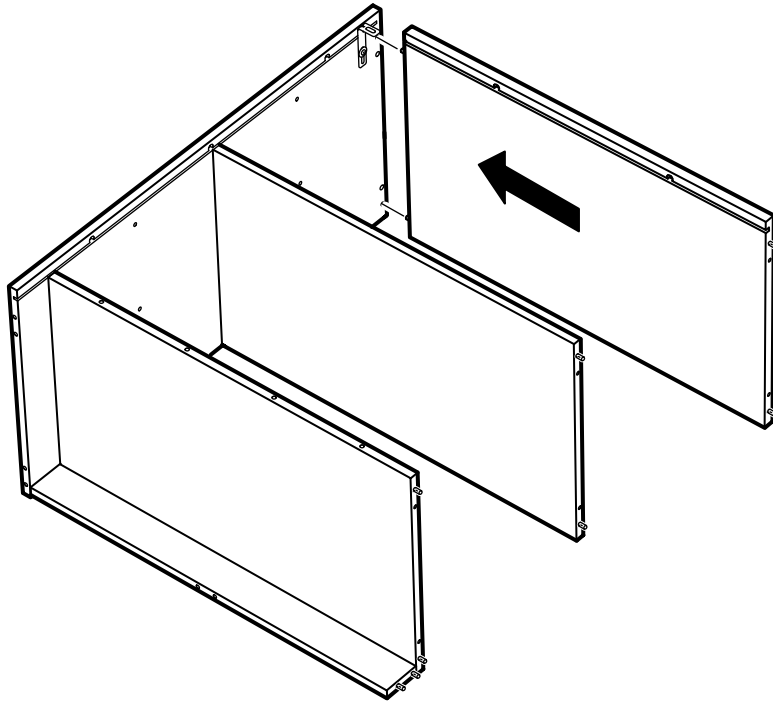

9

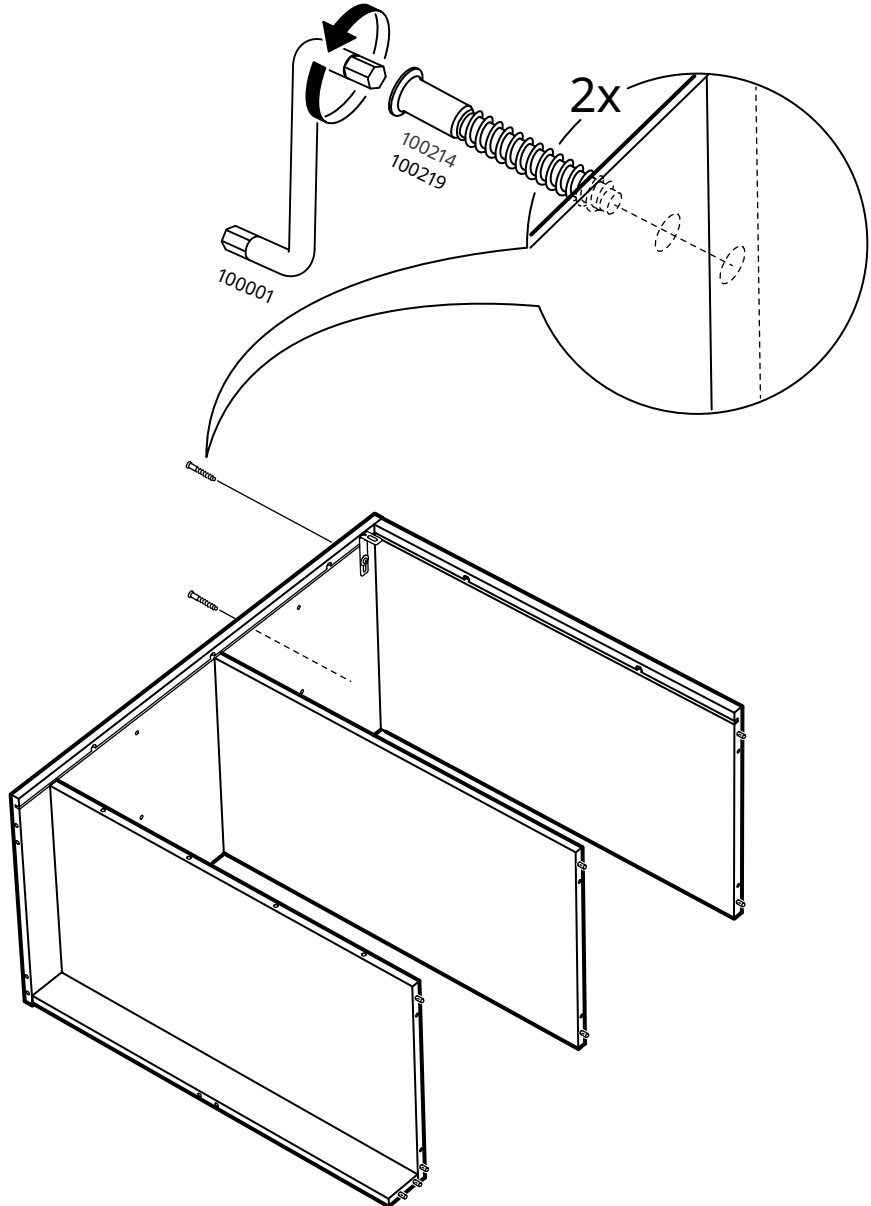

10

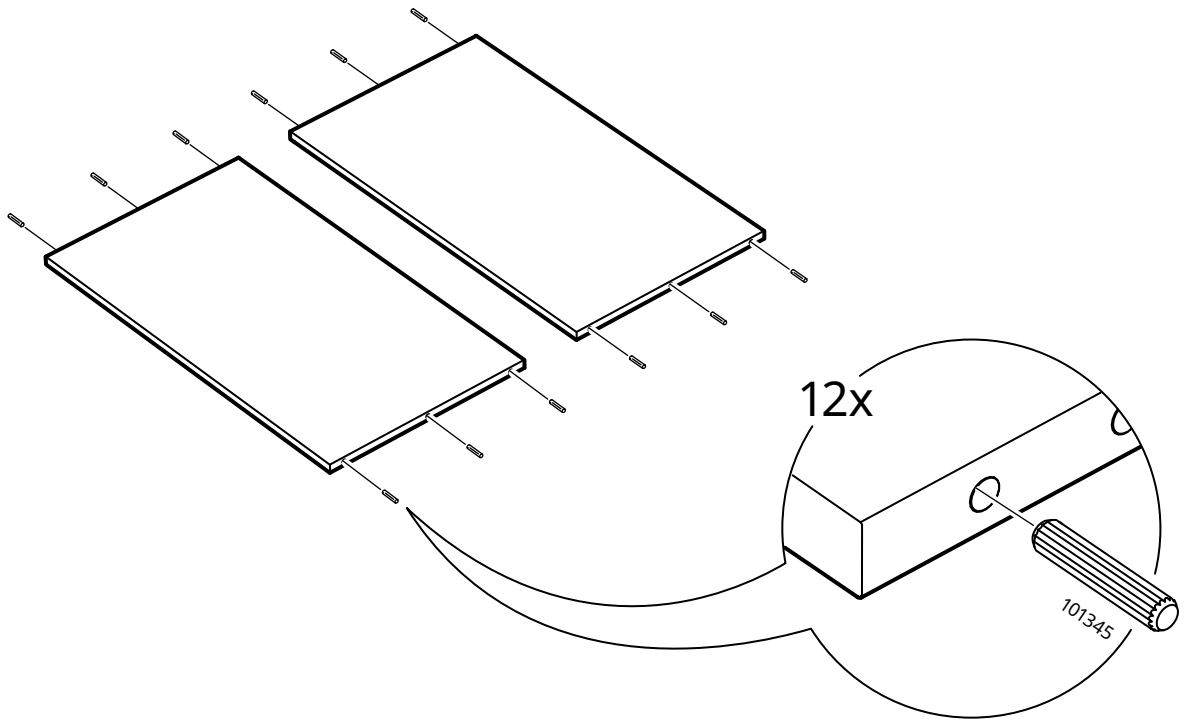

11

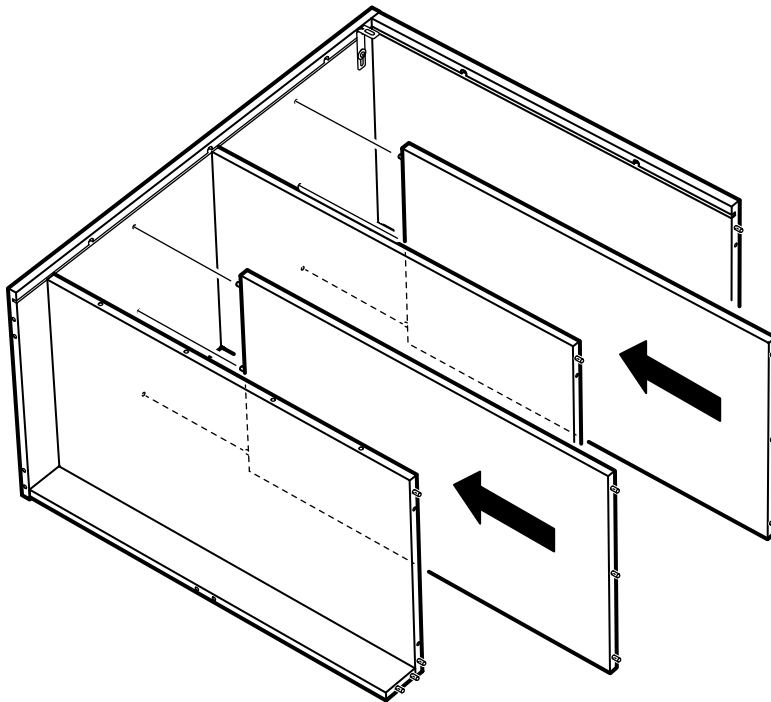

12

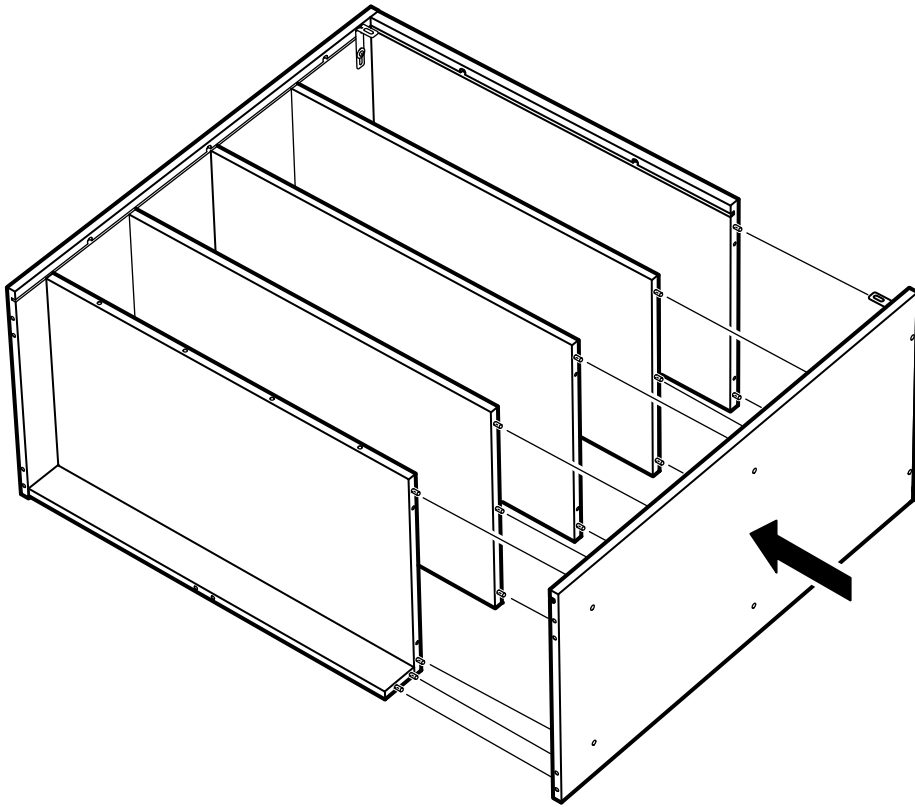

13

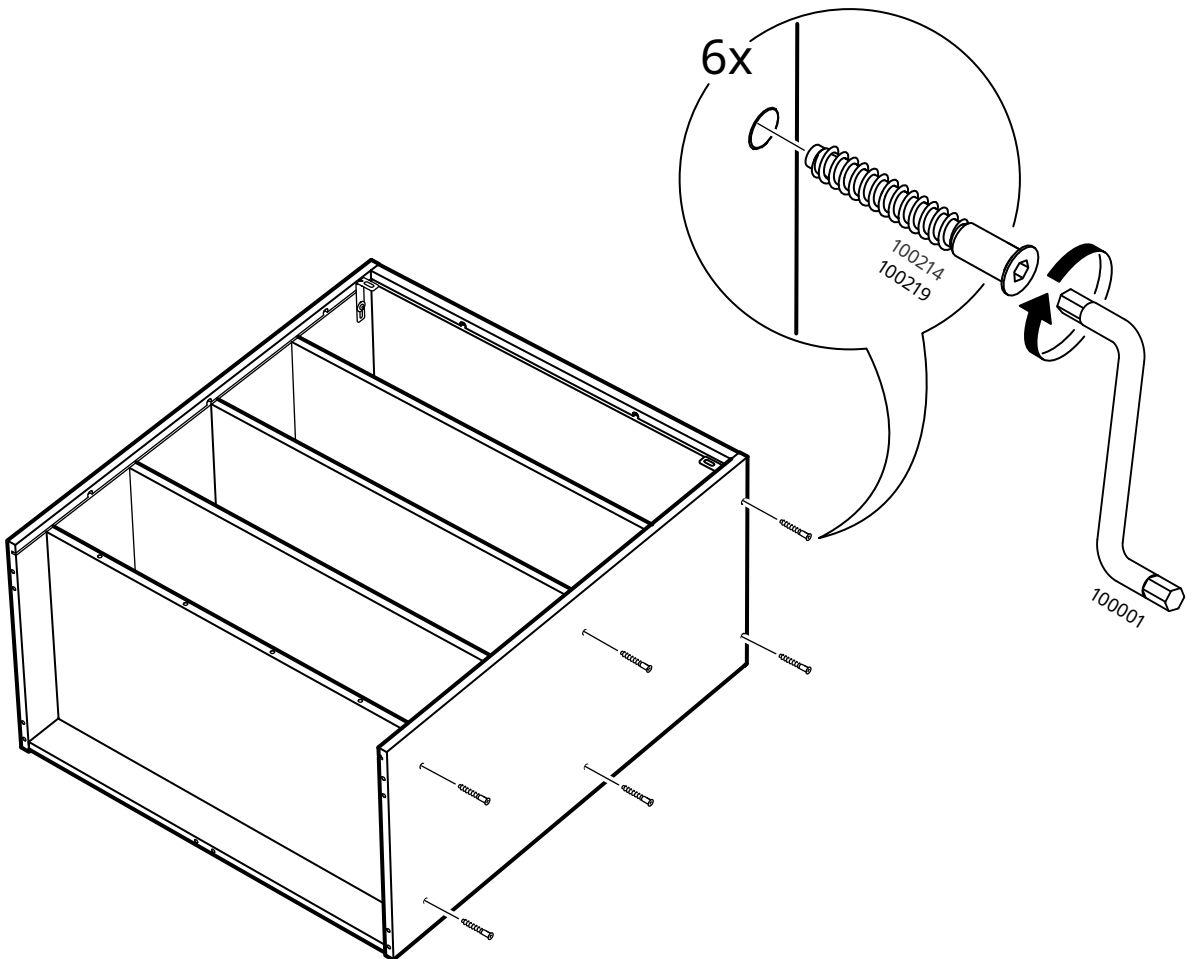

14

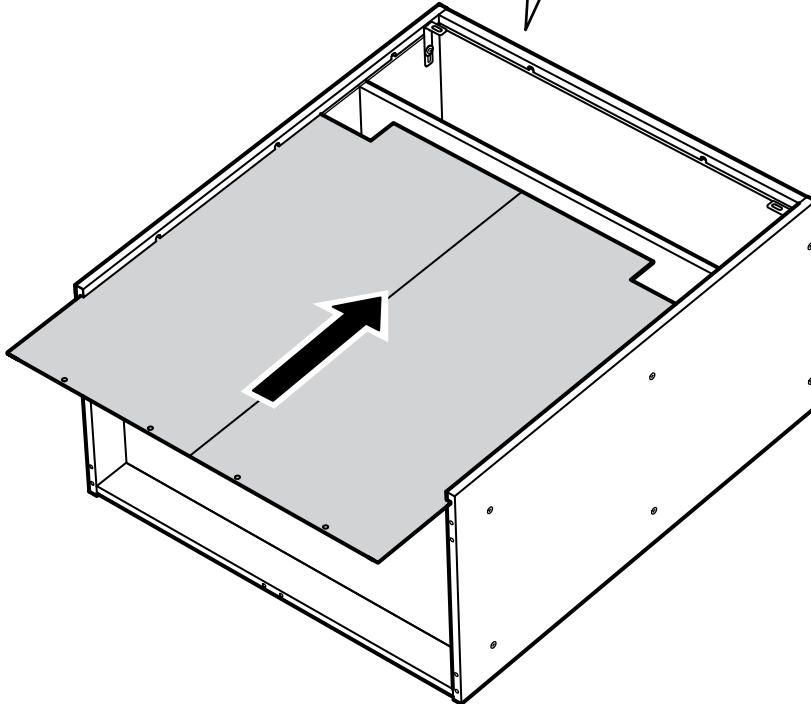
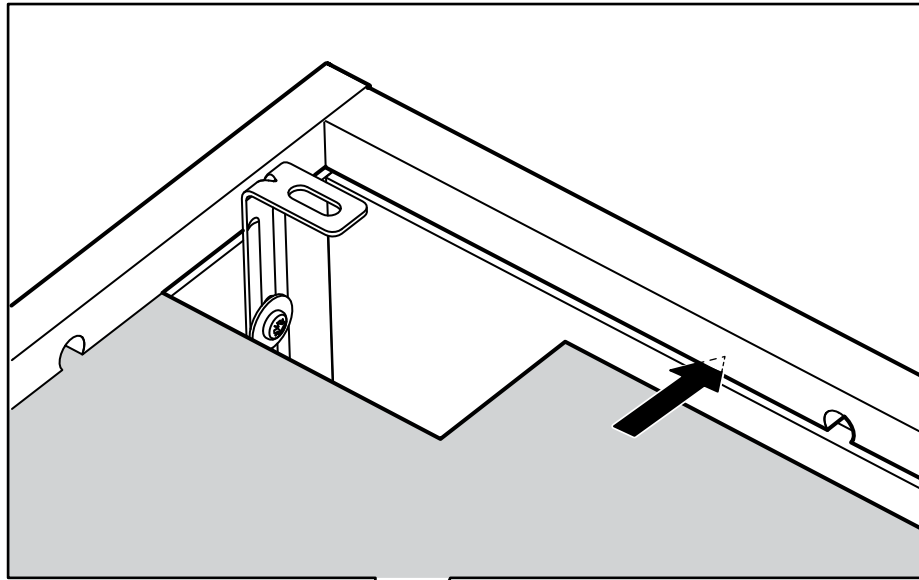

15

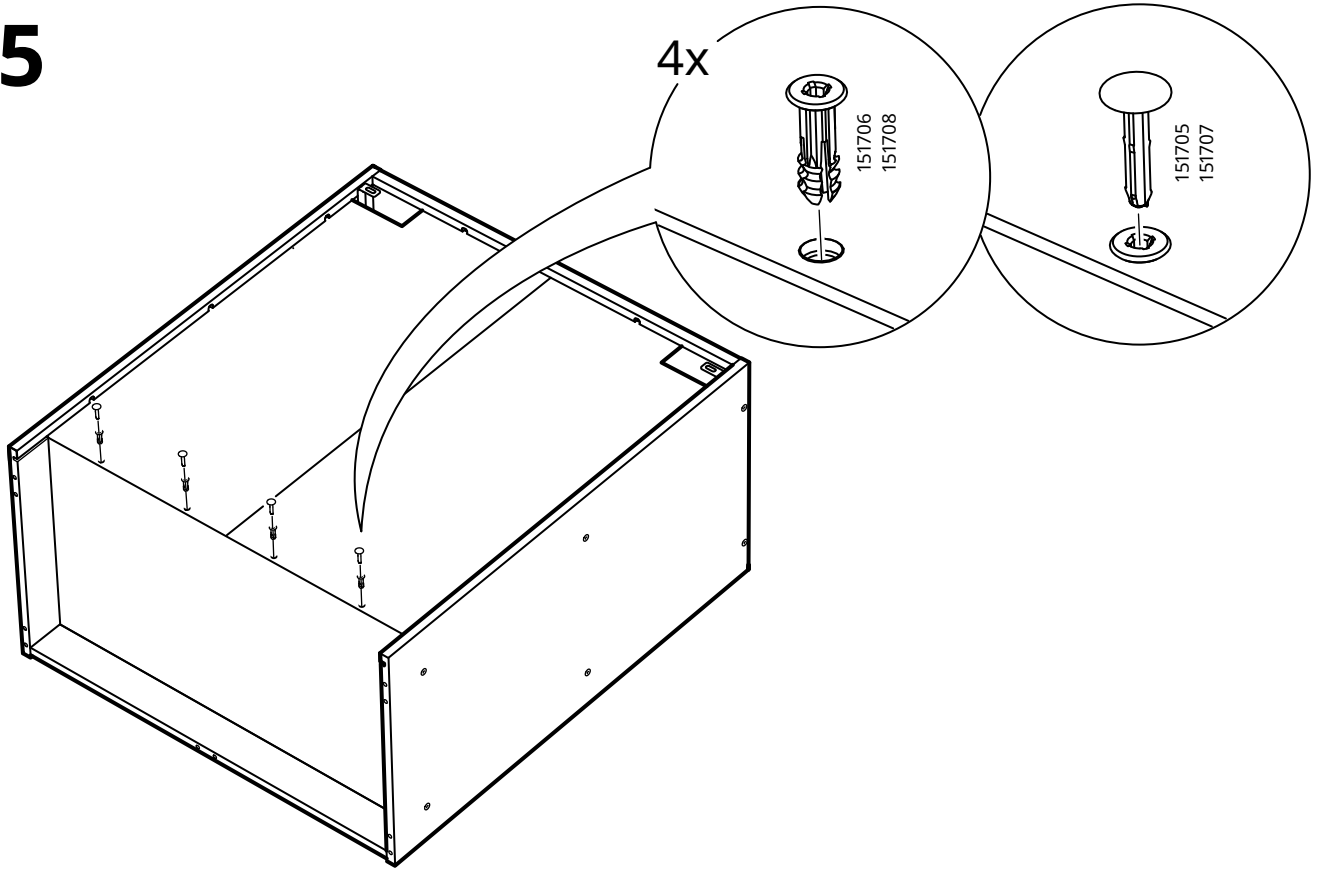

16

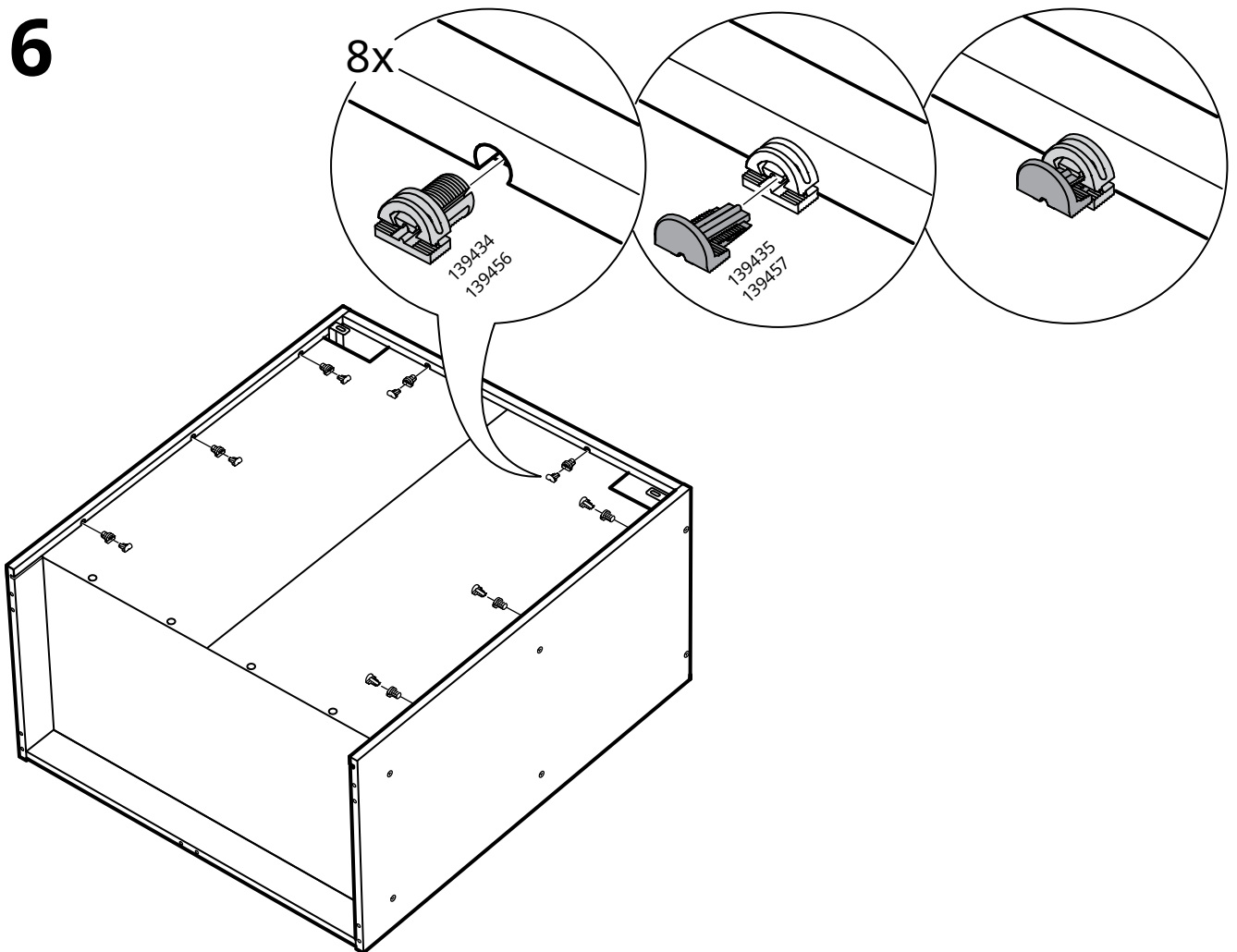

17

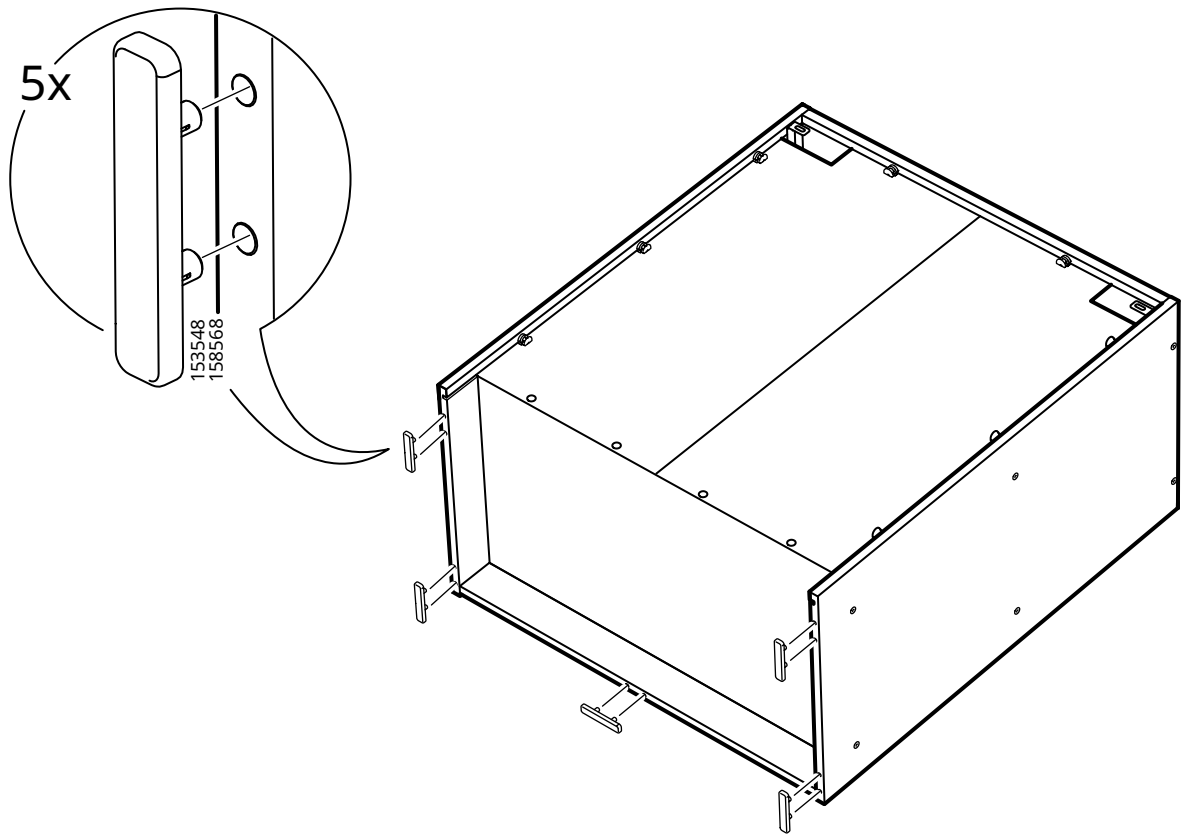

18

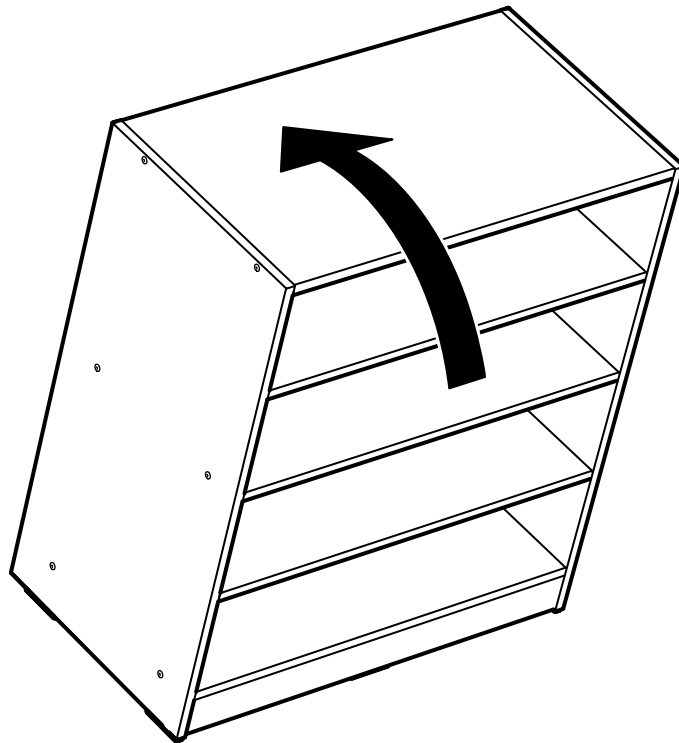

19

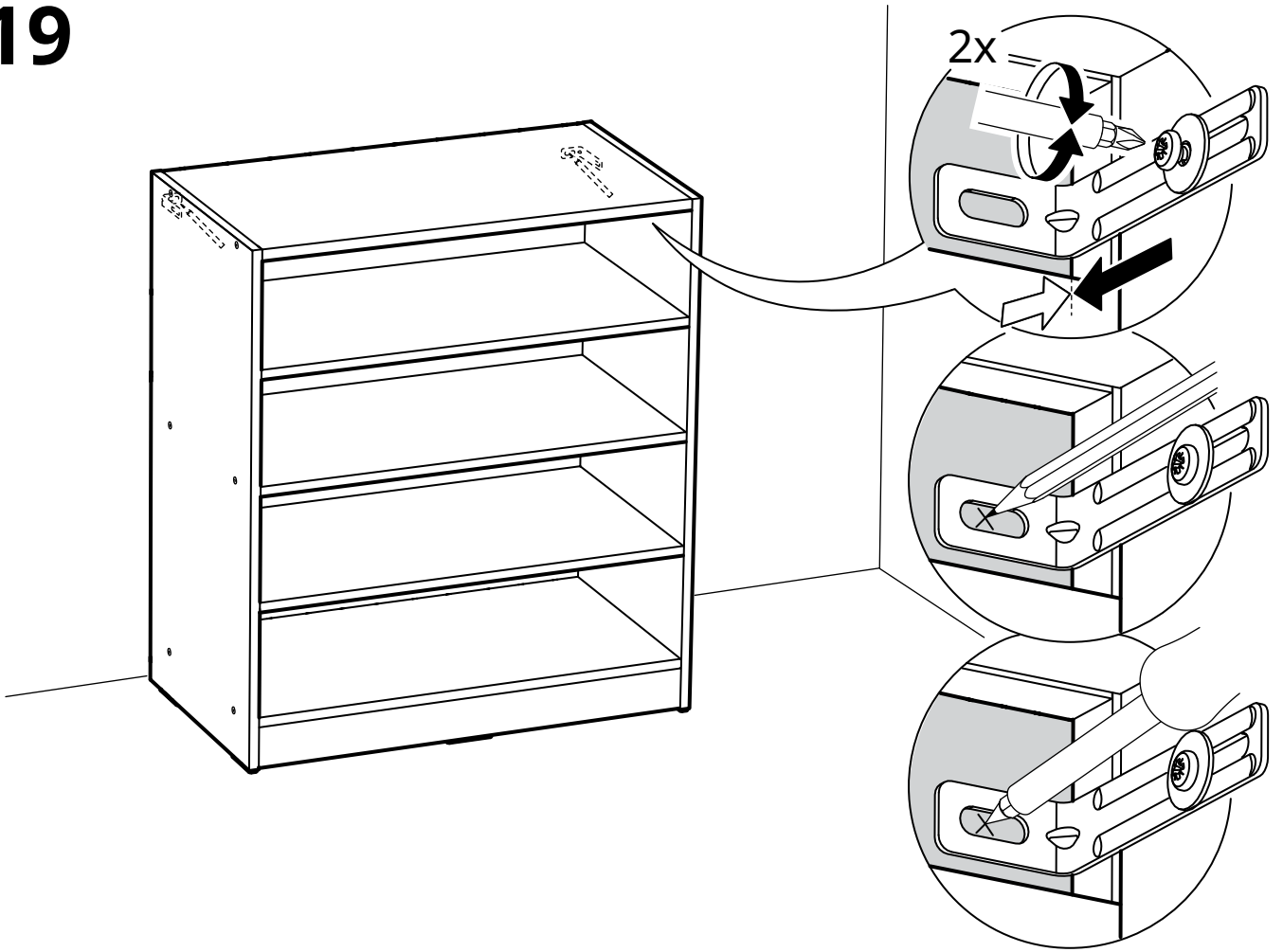

20

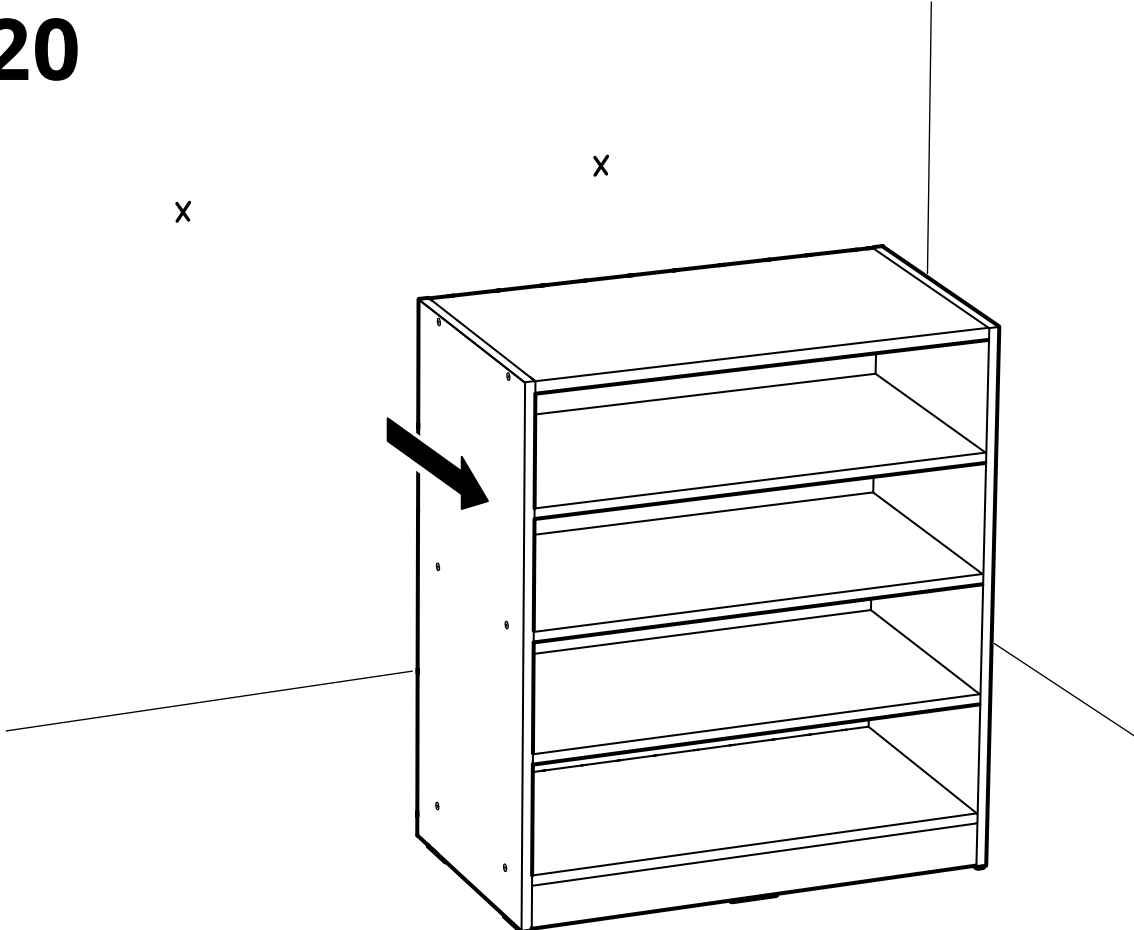

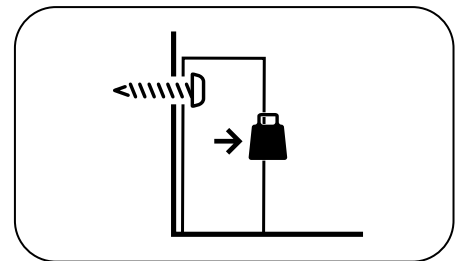

English

The screw(s) and plug(s) supplied can be used with most solid (A) and hollow (B) walls. For solid wood (C) use the screw(s) without plug(s). If you are uncertain, seek professional advice.

Español

Los tornillos y tacos incluidos se pueden utilizar en la mayor parte de las paredes sólidas (A) o huecas (B). Para la madera maciza (C), usa los tornillos sin tacos. Si tienes dudas, acude a un experto.

Portugues

Os parafusos e os pinos fornecidos podem ser usados na maior parte das paredes maciças (A) e ocas (B). Para madeira maciça (C), use parafusos sem pinos. Se não tiver a certeza, peça ajuda a um técnico especializado.

中文

产品随附的螺丝和螺栓适用于大部分实心 (A) 和空心 (B) 墙壁。实木墙壁 (C) 只需要使用螺丝, 不必搭配螺栓。如不确定适合的螺丝类型, 请咨询专业人士。

繁中

產品附的螺絲和壁虎適用於大部分的實心(A)和空心(B)牆壁。實木牆壁(C)應使用螺絲, 不需搭配壁虎。如果不確定適合的螺絲類型, 請洽詢服務人員。

한국어

제공된 나사와 플러그는 대부분의 단단한 벽(A)이나 중공벽(B)에 사용할 수 있습니다. 원목(C)에는 플러그없이 나사만 사용하세요. 반드시 전문가의 조언을 구하고 설치하세요.

日本語

付属のネジとプラグはほとんどの1枚壁 (A) や中空壁 (B) に使用できます。無垢材 (C) にはプラグなしネジをお使いください。取り付けに適したネジに関しては、専門店にご相談ください。

Bahasa Indonesia

Sekrup dan plug yang disediakan dapat digunakan dengan sebagian besar dinding padat (A) dan berlubang (B). Untuk kayu solid (C) gunakan sekrup tanpa plug. Jika Anda tidak yakin, cari saran profesional.

Bahasa Malaysia

Skrus dan palam yang dibekalkan boleh digunakan

pada kebanyakan dinding padat dan lompong. Untuk kayu padu gunakan skru tanpa palam. Jika anda kurang pasti, dapatkan nasihat profesional.

عربي

يمكن استخدام المسامير (المسامير) والحشوة (الحشوات) البلاستيكية المرفقة في معظم الجدران الصلبة (A) والمجوفة (B). أما مع الخشب الصلب (C), استخدم المسمار (المسامير) بدون حشوات. في حالة عدم المعرفة, يرجى طلب مساعدة في مختص.

ไทย

สกรูและพุกที่ให้มาสามารถใช้กับผนังที่แข็ง (A) และกลวง (B) ได้ เป็นส่วนมาก สำหรับผนังไม้แท้ (C) ให้ใช้เฉพาะสกรูโดยไม่ต้องใช้พุก หากไม่แน่ใจเรื่อง การเลือกและใช้วัสดุผนัง ควรสอบถามผู้เชี่ยวชาญ

Tiếng Việt

Ốc vít và tắc kê đi kèm có thể dùng với hầu hết các loại tường đặc (A) hoặc rỗng (B). Đối với gỗ đặc (C), sử dụng ốc vít và không dùng tắc kê. Nếu bạn không chắc chắn, hãy liên hệ với người có chuyên môn để được tư vấn.

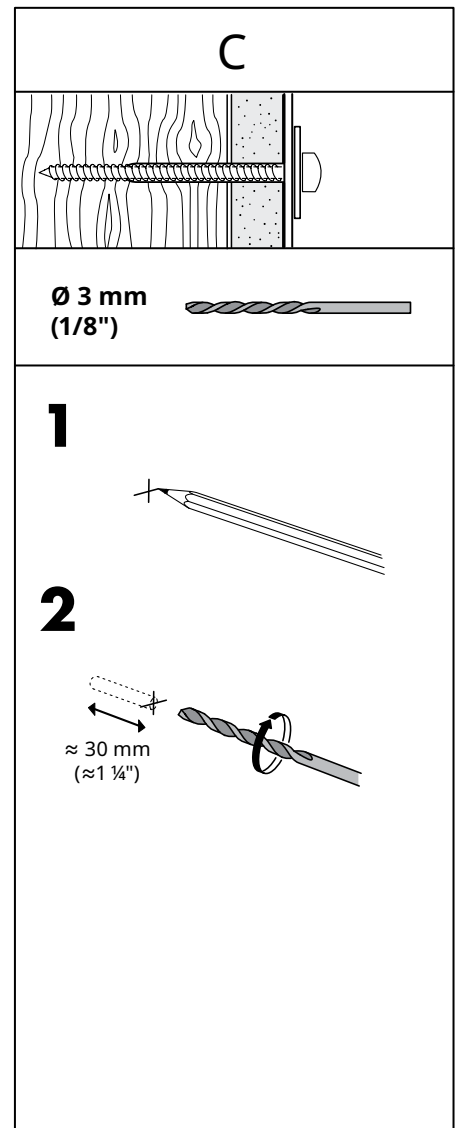
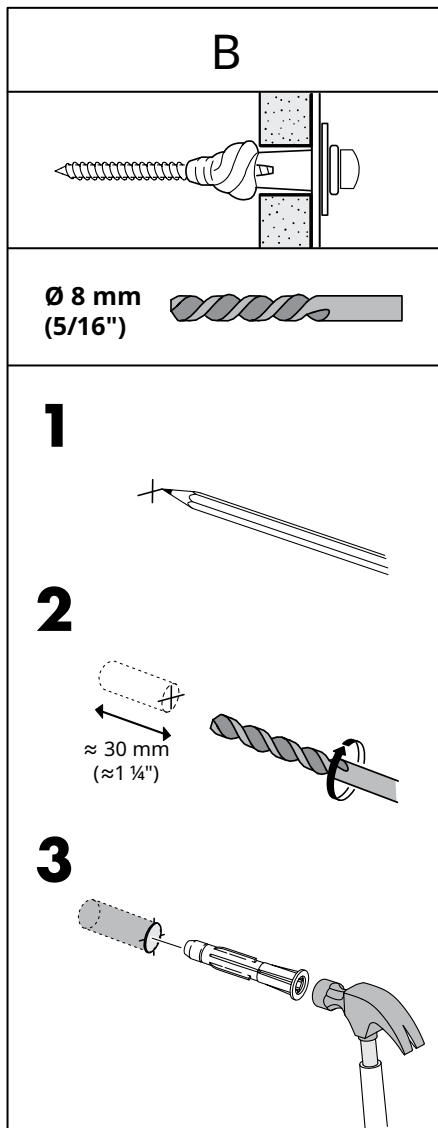
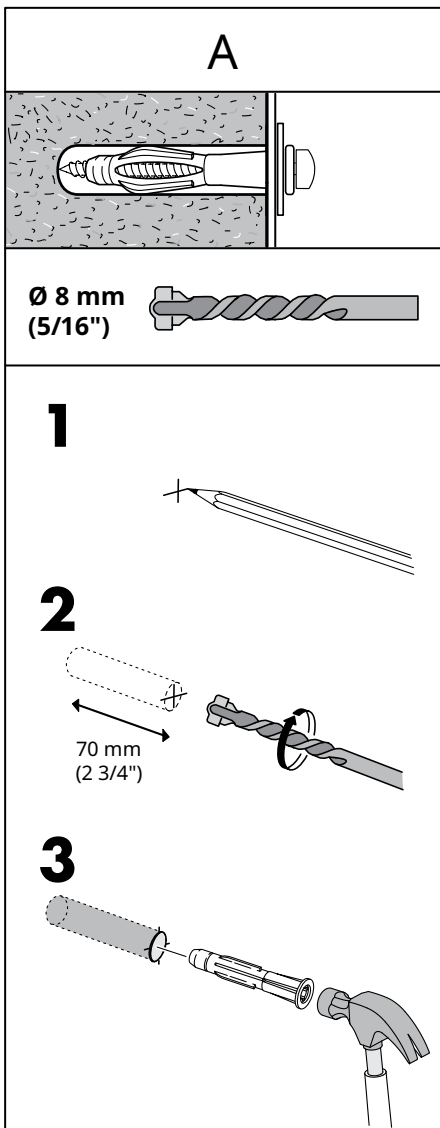

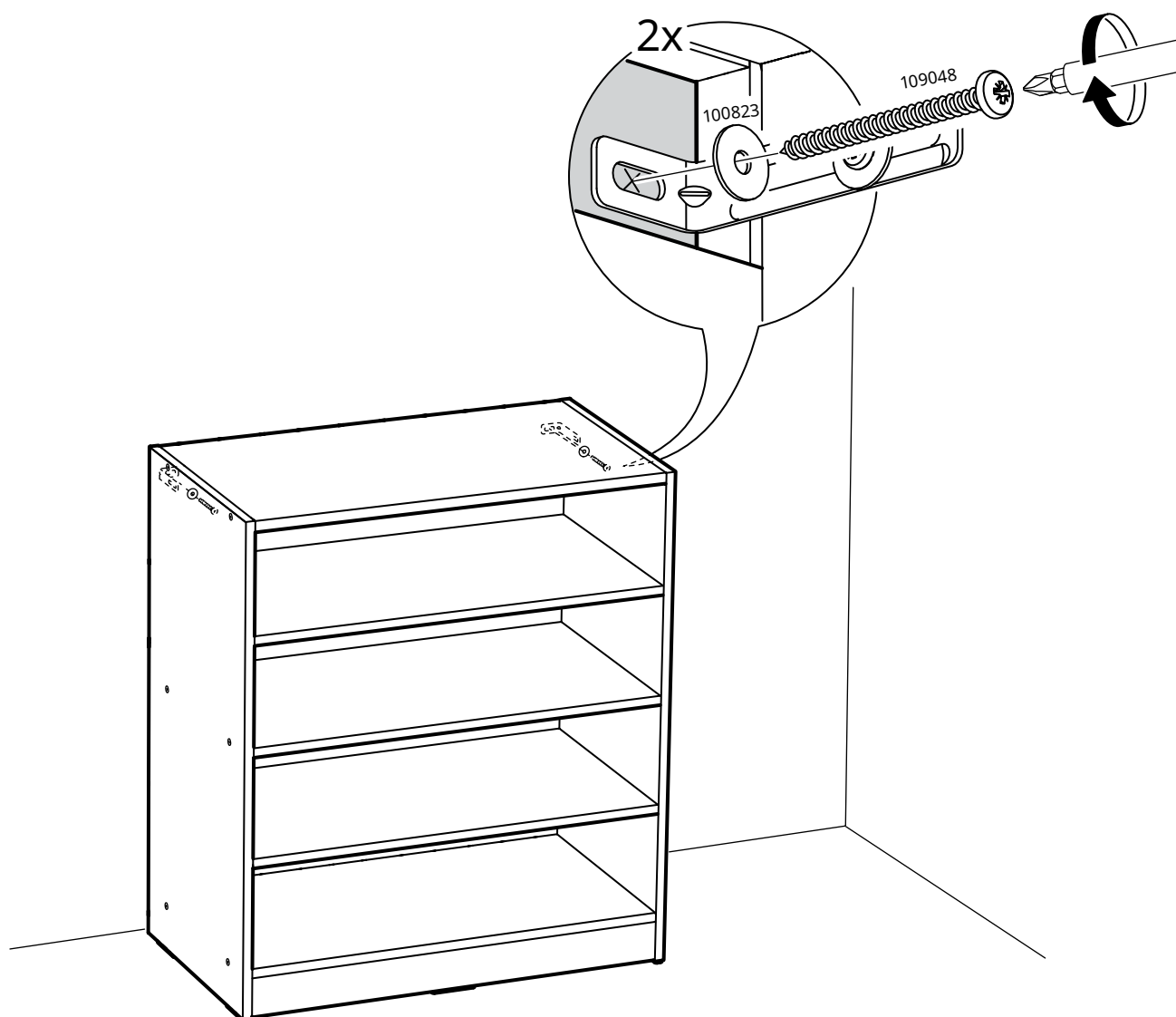

22

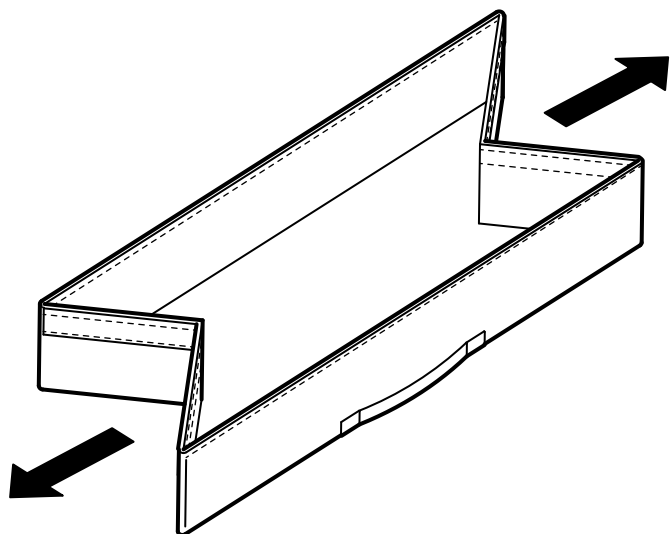

23

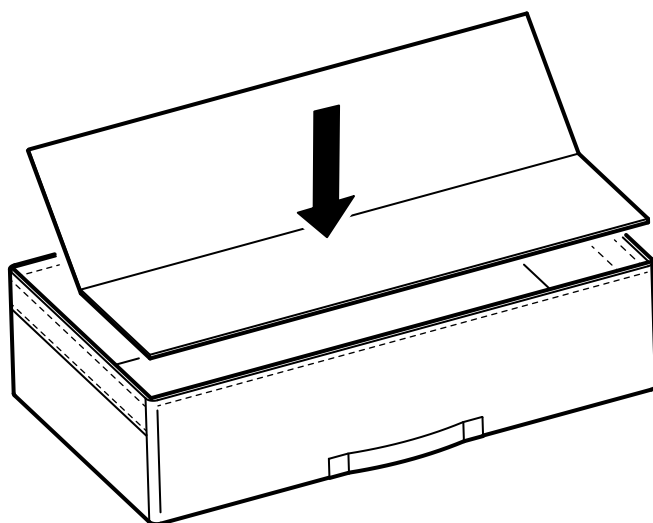

24

